

Equilibrium ball float valve with balanced single seat - Mod. ATHENA 1" - 1 1/4"

The ATHENA 1" - 1 1/4" is an equilibrium, single seat upstream pressure balanced float valve, which automatically controls the constant level of a tank or reservoir, regardless of upstream pressure variations, and shuts off when the maximum level is reached. Thanks to its exclusive technology this valve brings the concept of reliability and performance to the highest standards.



Technical features and benefits

- Body in ductile cast iron PN 16.
- Cover in brass or stainless steel provided with the self cleaning piston technology driving system.
- Mobile block containing the piston and obturator, both in stainless steel.
- The lever mechanism is made in zinc-plated or stainless steel and composed of a rod which, thanks to a system of pivots, puts the main shaft in communication with the float allowing the opening or closing of the valve.
- Designed for angle pattern installation only and to allow flow conveyance through the outlet.
- The valves modulates and throttle the inflow proportionally to the consumption, accuracy and perfect water-tightness is guaranteed also with low pressure values.
- Thanks to the upstream pressure balanced seat the movement of the obturator and valve performance is not affected by upstream pressure fluctuations, transient and unwanted surges are therefore avoided.
- Pipe (available on request) Ø 76,1X1,5 mm in stainless steel to convey the flow towards the tank.

Applications

- Water distribution systems.
- Fire protection storage tanks.
- Irrigation systems.
- Whenever the constant level regulation and control function is required.

Technical details

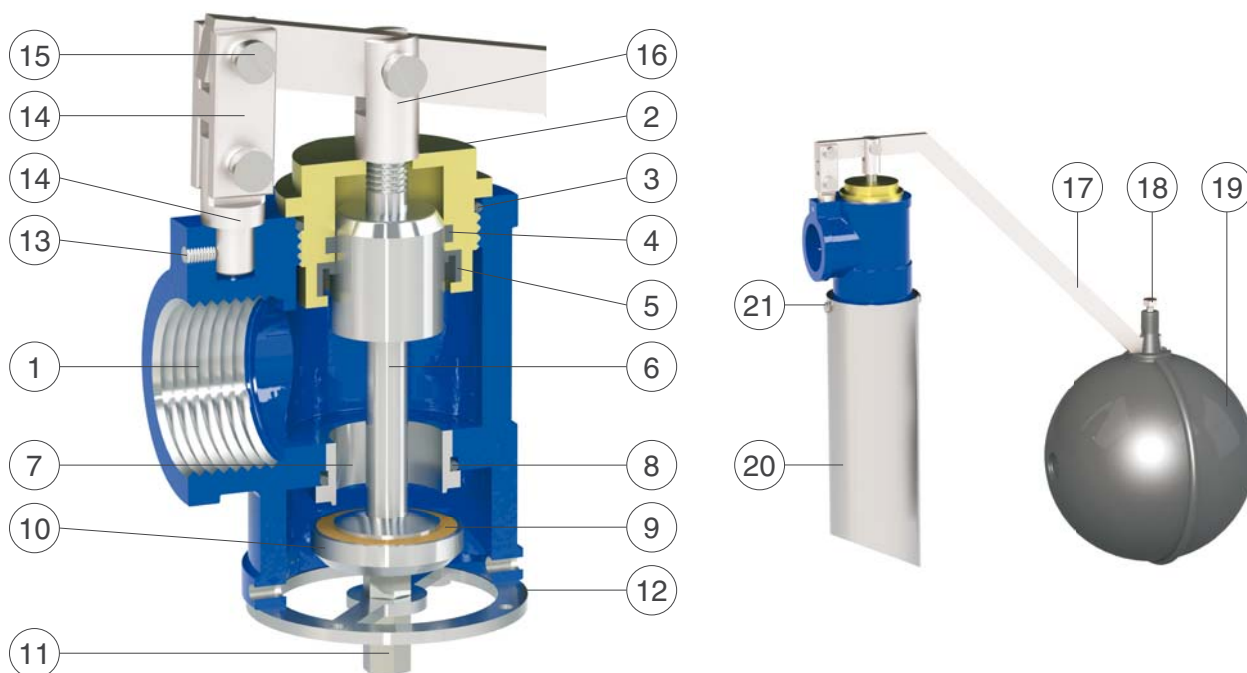

N.	Component	Standard material	Optional
1	Body	ductile cast iron GJS 450-10 or GJS 500-7	
2	Cap	brass	stainless s. AISI 303/316
3	O-ring	NBR	EPDM/Viton
4	Guiding ring	PTFE	
5	Gasket	NBR	EPDM/Viton
6	Piston with shaft	stainless steel AISI 303	stainless steel AISI 316
7	Seat	stainless steel AISI 303	stainless steel AISI 316
8	O-ring	NBR	EPDM/Viton
9	Plane gasket	NBR	polyurethane
10	Obturator	stainless steel AISI 303	stainless steel AISI 316
11	Tightening nut	stainless steel AISI 303	stainless steel AISI 316
12	Lower guiding ring	stainless steel AISI 304	stainless steel AISI 316
13	Plug	stainless steel AISI 304	stainless steel AISI 316
14	Upper and lower coupling	zinc-plated steel	stainless s. AISI 304/316
15	Pivots	stainless steel AISI 303	stainless steel AISI 316
16	Shaft coupling	zinc-plated steel	stainless steel AISI 316
17	Float lever	zinc-plated steel	stainless steel AISI 316
18	Screw	zinc-plated steel	stainless s. AISI 304/316
19	Float	polyethylene	stainless steel
20	Conveying pipe (optional)	stainless steel AISI 304	stainless steel AISI 316
21	Screws (optional)	stainless steel AISI 304	stainless steel AISI 316

The list of materials and components is subject to changes without notice.

Working conditions and head loss

Treated water maximum temperature 70°C.

Maximum pressure PN 16.

To avoid cavitation, recommended Δp 8 bar.

The Kv of the valve, meaning the flow rate expressed in m³/h producing a head loss of 1 bar, is 12,6.

Standard

Certified and tested in compliance with EN 1074/5.

Threaded BSP connections.

Epoxy painting applied through fluidized bed technology blue RAL 5005.

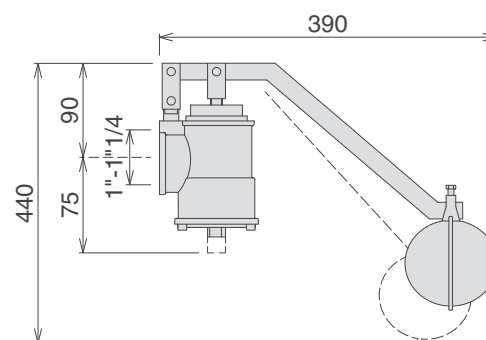

Values are approximate, consult us for more details.

Spare parts breakdown



Recommended flow rate

The following chart shows the recommended flow rate for the proper sizing of Athena valves.

Athena 1" - 1 1/4"

Flow rate min. (l/s)	0,1
Flow rate max. (l/s)	1,9
Emergency (l/s)	2,4