

Vertical check valves PN 16



VIT-122

Flange: UNI EN 1092-2 PN 16

Installation: any position

APPLICATIONS • Fire Fighting systems • Pumping stations • Heating – conditioning systems • Irrigation • Industry

Epoxy painting suitable for potable drinking water applications

The vertical check valves are the cheaper alternative to the venturi check valves. Thanks to the spring inside, the vertical check valves have excellent tightness and low water losses, they are maintenance-free.

Materials

body	cast iron GG25, EN-GJL-250
disc	cast iron GG25, EN-GJL-250
spring	stainless steel
disc seat facing	rubber
gasket	asbestos free
painting	epoxy

Dimensions

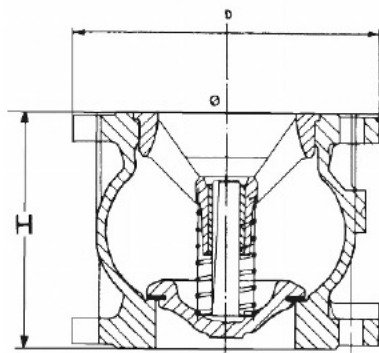

DN	H mm.	D mm.	Weight kg.
50	100	165	6
65	120	185	9
80	140	200	10.5
100	170	220	14
125	200	250	24
150	230	285	29.5
200	288/300	340	49.5
250	354/370	405	88
300	410	460	110

Pressure

DN	Nominal pressure	Test pressure Mpa		Max working pressure Mpa
mm	BAR	body	seat	90°C
50-300	16	2,4	1,76	1,6