

Cast steel swing check valves PN 40



VIT-194

Flanges: UNI EN 1092-2 PN 40

Face to face length: EN 558-1 serie 1, DIN 3202 F1

Installation: horizontal / vertical with down-up flow direction.

APPLICATIONS • Water supply • Pumping stations • Power stations • Industry • Steam • Oil & refineries

These swing check valves in cast steel PN 40 are manufactured with all parts in cast steel, and sealing seats in stainless steel. These swing check valves are installed for water, steam, gas, oil or whenever temperature doesn't allow the cast iron valves.

Materials

body	cast steel GS-C25, GP-240-GH
cover	cast steel GS-C25, GP-240-GH
swing	cast steel GS-C25, GP-240-GH
body and disc seat facing	stainless steel
gasket	graphite
painting	nitro enamel or epoxy

Dimensions

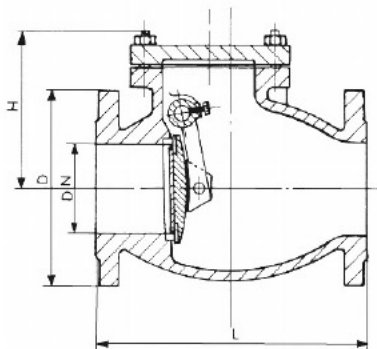

DN	L mm.	H mm.	D mm.	Peso Weight kg.
50	230	102	160	15
65	290	160	180	21.5
80	310	165	195	38
100	350	175	230	41
125	400	185	270	58
150	480	245	300	80
200	600	355	375	119
250	730	395	450	212
300	850	470	515	299.5
350	980	520	580	520
400	1100	600	660	570
500	1250	670	755	1025
600	1450	760	890	1650

Pressure

DN	Nominal pressure	Test pressure Mpa	Max working pressure Mpa		
mm	BAR	body	seat	150°C	400°C
50-600	40	6,0	4,4	3,42	2,31