

## OS & Y Resilient Seated Gate Valve Flanged Ends, 300PSI



### Specifications

Complies with AWWA C515 Standard  
 Heavy duty handwheel  
 High quality graphite stem seal  
 Flanges to ANSI B16. 1 Class125  
 (Other flange types available upon request  
 UL Listed and FM Approved

### Working Pressure

300PSI upto DN 300  
 200PSI / 250PSI from DN 350 to DN 600

### Working Temperature

-10 C to 82 C

### Corrosion Protection

Fusion Bonded Epoxy Coated Interior and Exterior to AWWA C550  
 Standard

### Note

Design and material are subject to change without notice

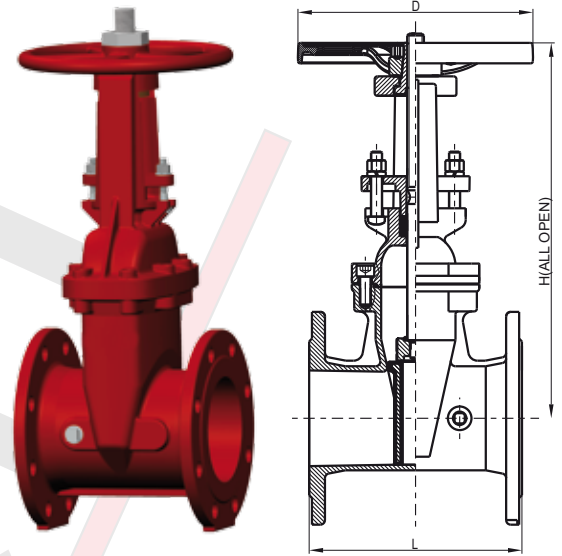

Fig . VIT-GTR-300

## Material Specification

No	Component	Material	Spec
1	Body	Ductile Iron	A536 65-45-12
2	Wedge	Ductile Iron, EPDM Encapsulated	
3	Wedge Nut	Stainless Steel	AISI 304
4	Stem	Stainless Steel	AISI 304
5	Bonnet	Ductile Iron	A536 65-45-12
6	Gasket	Rubber	EPDM
7	Packing	Graphite	Non Asbestos
8	Gland	Ductile Iron	A536 65-45-12
9	Yoke Nut	Bronze	B62 C83600
10	Handwheel	Ductile Iron	A536 65-45-12
11	Handwheel Nut	Ductile Iron	A536 65-45-12

## Dimensions (mm/inch)

Size	2.5"		3"		4"		5"		6"		8"		10"		12"	
	mm	inch	mm	inch	mm	inch	mm	inch	mm	inch	mm	inch	mm	inch	mm	inch
L	190.5	7-1/2	203	8	229	9	254	10	267	10-1/2	292	11-1/2	330	13	356	14
H(Open)	411	16.18	462	18.19	514	20.24	629	24.76	709	27.91	919	36.18	1116	43.94	1300	51.18
D	184	7-1/4	254	10	254	10	305	12	305	12	356	14	445	17-1/2	445	17-1/2

Size	350/14"		400/16"		450/18"		500/20"		600/24"	
	mm	inch	mm	inch	mm	inch	mm	inch	mm	inch
L	381	15	406	16	432	17	457	18	508	20
H(Open)	1577	62.09	1800	70.87	2048	80.63	2297	90.43	2600	102.36
D	508	20.00	558	21.57	610	24	610	24	762	30