

Swing Check Valve Flanged Ends, 300PSI

Specifications

Complies with AWWA C508 Standard, clear waterway design
Seating type is resilient material
Flanges to ANSI B16.1 Class 125 (Other flange types available upon request)

Working Pressure

300 PSI.
200 PSI and 250 PSI available on request

Working Temperature

-10°C to 82°C

Corrosion Protection

Fusion Bonded Epoxy Coated Interior and Exterior to AWWA C550 Standard

Note

Design and material are subject to change without notice



Fig. VIT-SCF-300

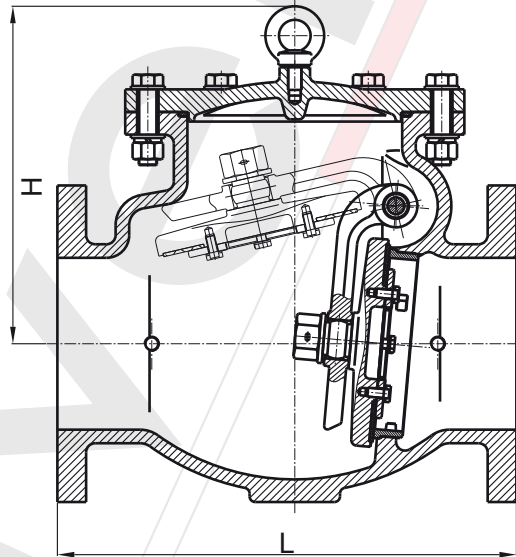

Material Specifications

No	Component	Material	Spec
1	Body	Ductile Iron	A536 65-45-12
2	Seat Ring	Rubber	EPDM
3	Disc	Ductile Iron	A536 65-45-12
4	Bonnet Cover	Ductile Iron	A536 65-45-12
5	Gasket	Rubber	EPDM
6	Hinge Pin	Stainless Steel	AISI 304
7	Clapper Arm	Ductile Iron	A536 65-45-12

Dimensions (mm/inch)

Size		2"	2.5"	3"	4"	5"	6"	8"	10"	12"
	L	mm	203	254	279	330	356	406	495	559
inch		8	10	11	13	14	16	19-1/2	22	26
H	mm	122	133	136.5	162.5	296	298.5	357	410	463
	inch	4.80	5.23	5.37	6.40	11.65	11.75	14.06	16.14	18.31