

IOM 1200AFBG.1
MAY 2006



TABLE OF CONTENTS:

DESCRIPTION	PAGE
Introduction	1
Valve Design & Function	2
Safety Warnings	3
Inspection and Storage	3
Installation	3 - 4
Maintenance	5 - 6
Test Procedure	7

LIST OF FIGURES

Fig. 1- Typical Tank Installation	2
Fig. 2- Pressure Relief - Operation	2
Fig. 3- Vacuum Relief - Operation	2
Fig. 4- Required Pallet Clearance	5
Fig. 5- Pallet Assembly Detail - FRP	6
Fig. 6- Pallet Assembly Detail - Kynar	6
Fig. 7- Typical Valve Cross-Section	6
Fig. 8- Model 1200A Valve	8
Fig. 9- Model 1220A Valve	9
Fig. 10- Model 1260A Valve	10
Fig. 11- Model 1300A Valve	11
Fig. 12- Model 1360A Valve	12
Fig. 13- Model 2300A Valve	13
Model Identification	15
Product Limited Warranty	15

LIST OF TABLES

Table 1 - Bolt Torque (Installation)	4
Table 2 - Fiberglass Valve Weights	4
Table 3 - Spare Parts P/N	5
Table 4 - Pallet Assembly Weights	6
Table 5 - List of Abbreviations	14
Table 6 - FRP Resin Options	14

INTRODUCTION:

Pressure and/or vacuum relief valves are used on liquid storage tanks and other process vessels or systems to prevent structural damage due to excess internal pressure or vacuum.

Storage tanks are pressurized when liquid is pumped in, compressing the existing vapor or when rising temperatures cause increased evaporation or expansion of existing vapor. Conversely, a vacuum condition may be created when pumping out or due to falling temperature. To prevent tank damage, vapor must be allowed into or out of the tank at specified pressure/vacuum conditions. The volume rate of

venting depends upon the tank size, volatility of the tank contents, the pumping rates and the temperature. Refer to API Standard 2000 for the procedures to determine venting requirements.

Relief valves must be carefully maintained by a qualified valve technician. It should only be assembled under clean conditions, preferably in a service shop environment. Carefully read and understand this manual before installing or attempting to repair a valve. Groth Corporation or a factory authorized repair center offers repair services for all products manufactured by the Tank Protection Division.

The table below shows the six different valve Models covered in this manual and indicates their Pressure (P) and/or Vacuum (V) relief capabilities.

Model	P	V	Description
1200A	✓	✓	Vent to atmosphere
1220A	✓	✓	Vent to Header
1260A/ 1760A	✓		Vent to Header
1300A		✓	Top mounted
1360A		✓	Side mounted
2300A	✓		Vent to atmosphere

For a list of abbreviations used in this manual, refer to page 14. For information not contained in this manual, please contact:

Groth Corporation
13650 N. Promenade Blvd
Stafford, Texas, 77477
281-295-6800(Phone)
281-295-6995(Fax)

The nameplate below shows the basic information that is listed for each relief valve:

GROTH CORPORATION HOUSTON TEXAS USA	MD: 1220A-03-666-T00		
	S/N: 776655H2		
	TAG: 123456-3		
FLANGE: 3" FF ANSI 150#			
SETTING	TYPE	% OP	FLOW [SCFH]
2 PSI	PRESS.	100	18,100
		30	10,700
1 PSI	VAC.	100	9,900

VALVE DESIGN AND FUNCTION:

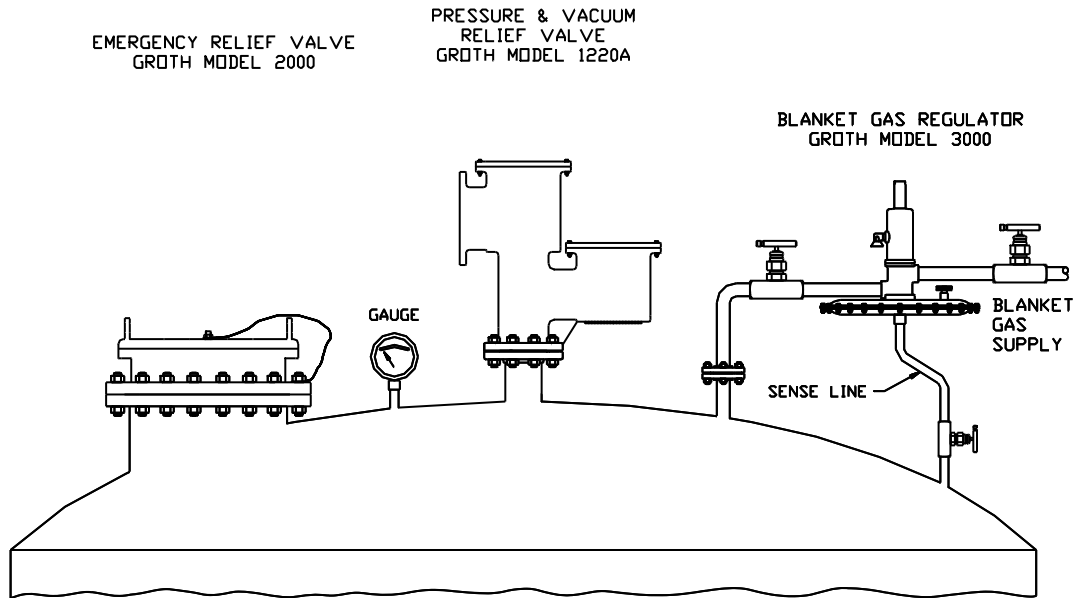

Fig. 1 - Typical Tank Installation

Tank protection equipment typically includes an operating valve which is designed to provide pressure/vacuum relief under normal pump in/out and thermal breathing conditions. An emergency relief valve can also provide both pressure and vacuum relief and normally it is sized to provide pressure relief if there is a fire in the immediate vicinity of the tank. It may also be sized by the tank designer to provide protection in the event of equipment failure (such as the rupture of a process steam line or an inert gas blanketing system failing “wide open”) or operator error.

A typical tank installation is shown in Fig. 1 which includes the following Groth products:

- Model 1220A ‘P/V’ Weight Loaded Valve
- Model 3000 Gas Blanketing Regulator
- Model 2000 Emergency ‘P’ Relief Valve

Pressure Relief: As the pressure in the storage tank increases, the vacuum pallet is held shut. When the set pressure is reached, the pressure pallet lifts and relieves to atmosphere (or to a header if it is a pipe away valve). See Fig. 2.

Vacuum Relief: As a vacuum is drawn in the storage tank (for example, when fluid is being pumped out), the pressure pallet is held shut by atmospheric pressure. When the vacuum setting is reached, the pallet lifts and air is drawn in from the atmosphere. See Fig. 3.

Installation Notes: (See Fig. 1 above)

1. Minimum clearance between tank roof and vacuum inlet port must be at least equal to the valves’ nominal flange bore.
2. Tank nozzle bore must be > or = valve inlet flange bore.
3. Inlet and outlet piping loads must be supported by appropriate structural supports, NOT by the valve body.

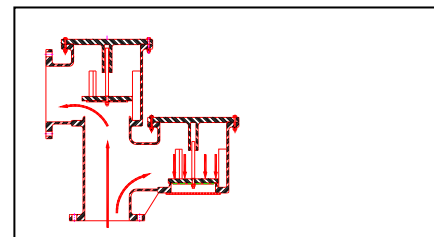

Fig. 2- Pressure Relief

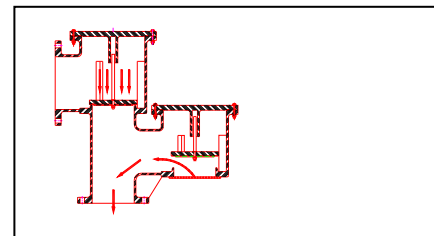

Fig. 3 - Vacuum Relief

SAFETY WARNINGS:

This section is an overview of safety guidelines that should be followed during the installation, operation and maintenance of Groth Pressure/Vacuum Relief Valves. To understand the context of these instructions and warnings, it is necessary to completely read and understand the contents of this manual.

The purpose of a weight loaded pressure/vacuum relief valve is to prevent excessive pressure or vacuum in a tank or process system. The valve must be designed for the proper MAWP and flow requirements of the system. Consult API Standard 2000 for tank protection sizing procedures. An improperly specified or functioning relief valve may result in structural damage to the tank or system, and can cause severe personal injury or death.

Valves are set at the factory according to purchase specifications. Do NOT change pressure ratings by adding additional weights to the pallet assembly without consulting the factory or your local Groth representative. Adding weights to a valve may restrict pallet lift and reduce the valves' rated flow capacity.

DO NOT mix pressure/vacuum pallet assemblies. Failure to ensure that both pallet assemblies are installed in the correct location can change the pressure and vacuum relief settings. This can cause a tank failure.

DO NOT attempt to remove the valve from the tank or process vessel without first bleeding all pressure from the system. ALTERNATIVE MEANS OF PRESSURE RELIEF MUST BE PROVIDED WHEN THE VALVE IS OUT OF SERVICE.

The valve has been exposed to process vapors while in service. Observe all plant procedures and Material Safety Data Sheets (MSDS) for the products in the system when inspecting, adjusting or servicing the valve. Take appropriate safety precautions regarding eye protection, respiration and skin contact.

The tank pressure required to discharge the normal or emergency venting requirements of the tank will be increased by the amount of back pressure in the discharge header, on a pipe away valve configuration. Maximum possible discharge header pressure must be considered when sizing the pressure relief valve.

INSPECTION AND STORAGE:

The pressure/vacuum relief valve is carefully packaged to prevent damage or contamination during shipping. Inspect all equipment when it is received; report any damage to the carrier immediately. The valve should be protected during handling and storage. Keep all the ports plugged to prevent intrusion of foreign materials. Before installation, inspect the unit for indications of physical damage or internal contamination. If these are observed, the valve must be disassembled, cleaned and repaired before installation.

INSTALLATION:

A typical valve installation on a tank or vessel is illustrated in Fig.1 on Page 2 using a Model 1220A Pressure/Vacuum Relief Valve.

Groth's weight loaded Pressure/Vacuum Relief Valves are designed to provide tank protection for both pressure and/or vacuum to +/-1 PSIG settings. The valves provide full rated flow capacity at 100% over-pressure. Consult factory for performance under other conditions.

WARNING: *All valves must be installed level as shown in Fig 1. To achieve nominal flow capacity, the tank nozzle bore must be at least the same nominal dimension as the relief valve inlet port.*

This series of valves all have 150# ANSI flange drilling compatibility. Torque guidelines are listed in Table 1. The valves are NOT rated for full flange pressure and do not require high bolting torque. Consult factory for special applications.

The following guidelines should be observed at installation:

1. Inspect the gasket seating surface of the tank nozzle flange. It must be clean, free of scratches, corrosion, tool marks, and flat.
2. Fiberglass valves are furnished with flat face flanges; they must ONLY be installed on a mating flat face flange with a full faced gasket.
3. Inspect the gasket; make sure that the material is suitable for the application.
4. Lubricate all studs and nuts with an appropriate thread lubricant. If the valve will see high temperature service or stainless steel fasteners are used, apply an anti-seize compound such as moly-disulfide.
5. Center the gasket within the bolt circle.
6. Lift the valve carefully using one or more fabric slings to support both pressure & vacuum chambers.
7. Set the valve carefully on the nozzle. Install the studs & tighten nuts hand tight.
8. Torque all fasteners to half the value listed in Table 1 in a staggered, alternating pattern.
9. Make sure that the flanges are not distorted and that the gasket is evenly compressed. Make up the final torque and check that no further nut rotation occurs at the torque value specified in Table 1 below:

TABLE 1 - Bolt Torque & Stud Specifications - ANSI #150 FF Flange Connections

Mounting Flange	Bolt Torque		Number Bolts Total	Stud Specifications		
	Flat Face Lb. - Ft.	kg. - m		Thread UNC	Stud Length	Qty
2"	25	3.5	4	5/8" - 11	3.00	4
3"	40	5.5	4	5/8" - 11	3.50	4
4"	40	5.5	8	5/8" - 11	3.50	8
6"	40	5.5	8	3/4" - 10	3.75	8
8"	55	7.5	8	3/4" - 10	4.00	8
10"	60	8.5	12	7/8" - 9	4.50	12
12"	80	11.0	12	7/8" - 9	4.50	12

Notes:

1. Do **NOT** bolt a **FF** FRP body to a **RF** tank nozzle.
2. Stud Length is based on standard ANSI mating flange, standard hex nut and two narrow series flat washers.

TABLE 2 – Fiberglass Valve Weights

Size	1200A		1220A		1260A/1760A		1300A		1360A		2300A	
	Lb.	Kg.	Lb.	Kg.	Lb.	Kg.	Lb.	Kg.	Lb.	Kg.	Lb.	Kg.
2"	18	8.3	20	9.3	13	5.9	5	2.3	8	3.8	10	4.4
3"	32	14.6	36	16.4	23	10.4	10	4.4	11	4.8	18	8.0
4"	49	22.5	55	24.9	36	16.5	15	7.0	16	7.3	26	11.9
6"	101	45.7	114	51.8	73	33.3	29	13.1	31	14.1	51	23.2
8"	149	67.8	168	76.6	112	50.7	46	20.7	44	20.1	78	35.5
10"	219	99.4	233	105.9	159	72.2	66	29.9	60	27.5	123	55.7
12"	289	131.6	314	142.7	216	98.1	95	43.2	77	34.9	167	76.0

Note: Based on pressure setting = 1 PSIG & Vacuum setting = 2 Oz./Sq.In. (where applicable)

MAINTENANCE:

Groth Corporation recommends that all service performed on a pressure/vacuum relief valve be done at the factory or a factory authorized repair center. Trained mechanics with specialized test equipment will ensure that the valve is accurately set.

It is important to regularly inspect the diaphragm, guides (body & cover) and seating surfaces to ensure the valve can open freely. Refer to Fig. 5 - 7 on the next page which illustrate a typical Pressure/Vacuum relief valve when disassembling the unit. Also inspect the valve body – especially at all tie-ins between flange & pipe sections for signs of corrosion or deterioration.

WARNING: Before disassembling valve carefully read and understand the Safety Warnings listed on page 3.

1. Loosen and remove all nuts and washers.
2. Lift off the pressure and/or vacuum cover(s). The weatherhood and weatherhood posts have a snug fit. Loosen the hex nuts that retain the weatherhood posts in the body a few turns; this will allow the weatherhood to be removed easily.
3. Remove the pressure and/or pallet assembly(s) by firmly grasping the stem and lifting straight up. Depending on the pressure/vacuum settings of the particular valve, weight plates are added to the pallet assembly. (Note that in most instances, these are integral with the pallet.) The weights and pallets **MUST** be reinstalled in their original locations. Make sure that all weight plates stay with the appropriate pallet assembly. Tag the assemblies "Pressure" and "Vacuum" as they are removed from the valve.
4. Carefully inspect the body for corrosion, damage or product build up. Also inspect the guide hole in the vacuum cover. Check the seating surfaces for pitting, corrosion or product build up.

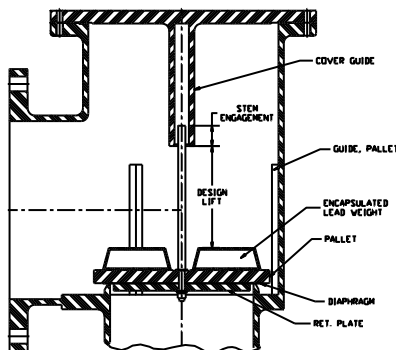

Fig. 4
Required
Pallet
Clearance

It is recommended that all soft goods including diaphragms, O-Rings and cover gasket are replaced. For a list of recommended spare parts see the drawings on pages 8 – 13.

NOTE: If the seat(s) are damaged, it is recommended that the body be returned to the factory for repairs.

5. If the stems are replaced, verify that the replacement component is the same length as the original stem. Note that stem engagement in the guide is approximately 0.75" for 2" - 4" sizes and 1.00" for 6" - 12" sizes.

6. Verify that the pallet assembly(s) are installed in the proper location. Assemble in reverse order. Make sure that pallet is flat on the seat and that the stem is not cocked at an angle when the weatherhood and pressure/vacuum cover(s) are installed. Tighten all fasteners firmly.

WARNING: When assembling a P/V valve, always use the correct length stem, put the pressure and vacuum pallet assembly(s) back in their original location and ensure that the stem is straight and fits into the guide in the cover or weatherhood.

1. If the stem length is too long, pallet lift will be restricted; the valve will not attain its full rated flow capacity.
2. If the pressure and vacuum pallet assemblies are mixed at assembly, the settings will be changed.
3. If the stem is cocked at an angle, pallet lift may be completely blocked.

An over-pressure can occur if any of these three conditions happens. This can cause a tank failure, severe personal injury and material damage.

Required Pallet Clearance		
Size	Pressure	Vacuum
2"	1.3"	1"
3"	1.95"	1.5"
4"	2.6"	2"
6"	3.9"	3"
8"	5.2"	4"
10"	6.5"	5"
12"	7.8"	6"

TABLE 3: Part Numbers - Spare Parts *

Component	Stem	Valve Size						
		2"	3"	4"	6"	8"	10"	12"
Dphgm, 10 mil FEP	Alloy C276	83064001	82561001	82358001	82412001	82283001	83173001	82376001
Dphgm, 20 mil FEP	Alloy C276	83064002	82561002	82358002	82412002	82283002	83173002	82376002
Dphgm, 10 mil FEP	PVDF	83064101	82561101	82358101	82412101	82283101	83173101	82376101
Dphgm, 20 mil FEP	PVDF	83064102	82561102	82358102	82412102	82283102	83173102	82376102
Gasket	-----	83065001	82562001	82352001	82414001	82282001	83697001	91018001

Setting	< 4 OSI		4 - 8 OSI		8 - 12 OSI		12 - 16 OSI	
Diaphragm	10 mil	20 mil	10 mil	20 mil	10 mil	20 mil	10 mil	20 mil
Quantity	1	---	---	1	1	1	---	2

* Please provide the valve serial number and pressure/vacuum setting(s) when ordering replacement pallet assembly components.

Fig. 5 - Pallet Assembly Detail – FRP/Alloy C276

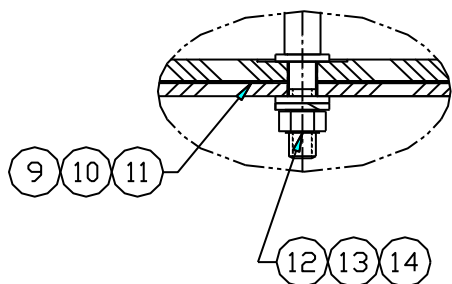
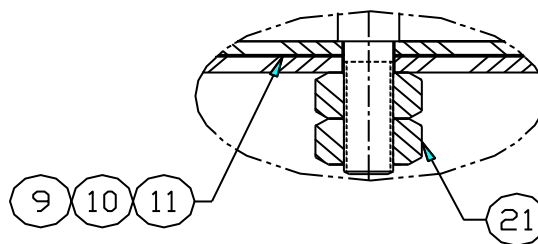

Fig. 6 - Pallet Assembly Detail – All PVDF



Standard pallet assembly components are the specified FRP material with Alloy C276 stem (if the pressure or vacuum setting is above the minimum setting). The pallet, retainer plate and diaphragm are attached to the stem with a flat washer, lock washer and hex nut which are generally noted as items 12, 13 & 14 for each available model.

If the pressure or vacuum setting is lower than what can be attained with the standard FRP/Alloy C276 pallet assembly, an all PVDF assembly is available. The pallet, retainer plate and diaphragm are attached to the stem using double Fluoropolymer hex nuts (Item 21). The all PVDF assembly is available for both pressure and vacuum ports for all models and sizes.

The drawings of all six models follow in Figures 8 – 13. Representative Bill of Materials are structured as follows for each model.

- Column 1: Epoxy Vinyl Ester Presin 411-45 FRP with Alloy C276 internal metal components.
- Column 2: Epoxy Vinyl Ester Presin 411-45 FRP with PVDF pallet assemblies.
- Column 3: Epoxy Vinyl Ester Presin 470-36 FRP with Alloy C276 internal metal components.
- Column 4: Furan FRP with Alloy C276 internal metal components.

Note that the PVDF pallet assemblies can be used with any FRP material.

TEST PROCEDURE:

1. A chart showing nominal pallet assembly weights for three common units of pressure is shown below in Table 4. Before starting to reassemble a valve, calculate the nominal pressure and vacuum pallet assembly weights. Weigh both pallet assemblies to ensure the correct settings.

2. After final assembly, mount the valve on a Tank Vent Test Stand (TVTS) and slowly raise the pressure at the flow rate specified below:

Valve Size	Test Flow Rate
2" - 6"	0.5 SCFH
8" - 12"	5.0 SCFH

ACCEPTANCE CRITERIA: The pressure gauge shall maintain a pressure equal to or greater than 75% of set pressure for a one minute period while the specified flow rate is maintained.

3. If the valve fails to meet the 75% criteria, it must be disassembled and the seat, pallet, and or diaphragms repaired or replaced.

4. Complete a Test Report indicating the actual pallet assembly weight and the peak pressure achieved at the specified Test Flow Rate.

5. A copy of the Test Report shall be maintained with the Valve Maintenance Records.

TABLE 4 - Nominal Pallet Assembly Weight Per Unit of Pressure (*)

SET	Valve Size													
	2"		3"		4"		6"		8"		10"		12"	
	[Lb.]	[kg]	[Lb.]	[kg]	[Lb.]	[kg]	[Lb.]	[kg]	[Lb.]	[kg]	[Lb.]	[kg]	[Lb.]	[kg]
1.0 OSI	0.22	0.10	0.48	0.22	0.84	0.38	1.84	0.84	3.24	1.47	5.03	2.29	7.22	3.28
1.0 IN WC	0.13	0.06	0.28	0.13	0.48	0.22	1.06	0.48	1.87	0.85	2.91	1.32	4.17	1.90
1.0 mbar	0.05	0.02	0.11	0.05	0.19	0.09	0.43	0.19	0.75	0.34	1.17	0.53	1.67	0.76

Example: Pallet Assembly Weight Calculation (PAW)

6" Valve set at 7.5 OSI

Read weight at 1.0 OSI from table
Multiple weight by set pressure

Weight = 1.84 Lb.

PAW (*) = 1.84 x 7.5 = 13.8 Lb.

(*) = Includes pallet, retainer plate, stem, diaphragm, weight plates (integral w/ pallet) & fasteners.

Groth Model 1200A Pressure/Vacuum Relief Valve

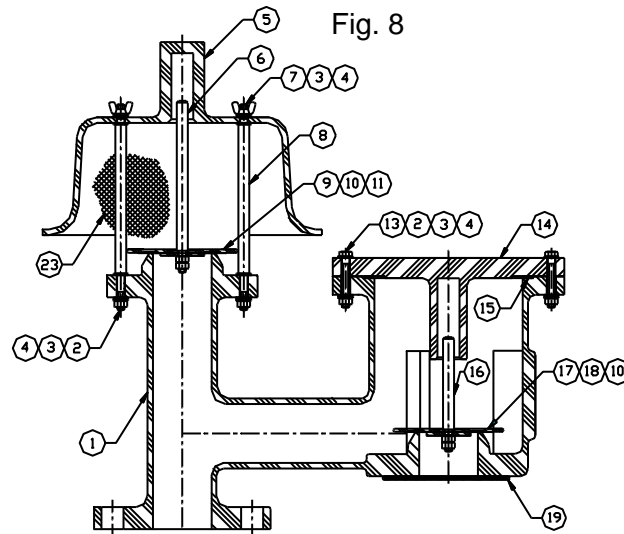

ITEM	DESCRIPTION	Epoxy Vinyl Ester Resin			
		411-45	411-45 – PVDF	470-36	Furan
1	Body	411-45	411-45	470-36	Furan
2	Hex Nut	316 SS	316 SS	316 SS	316 SS
3	Lock Washer	316 SS	316 SS	316 SS	316 SS
4	Flat Washer	316 SS	316 SS	316 SS	316 SS
5	Weatherhood	411-45	411-45	470-36	Furan
6	Stem-Pressure	Alloy C276	PVDF	Alloy C276	Alloy C276
7	Nut	316 SS	316 SS	316 SS	316 SS
8	Weatherhood Post	Alloy C276	Alloy C276	Alloy C276	Alloy C276
9	Pallet-Pressure	411-45	PVDF	470-36	Furan
10	* Diaphragm (Press/Vac.)	FEP	FEP	FEP	FEP
11	Retainer Plate-Pressure	411-45	PVDF	470-36	Furan
12	Hex Nut	Not Used	Floropolymer	Not Used	Not Used
13	Hex Bolt	316 SS	316 SS	316 SS	316 SS
14	Cover	411-45	411-45	470-36	Furan
15	* Gasket-Cover *	Floropolymer	Floropolymer	Floropolymer	Floropolymer
16	Stem-Vacuum	Alloy C276	PVDF	Alloy C276	Alloy C276
17	Pallet-Vacuum	411-45	PVDF	470-36	Furan
18	Retainer Plate-Vacuum	411-45	Kynar	470-36	Furan
19	Screen – Vacuum (Optional)	PVC	PVC	PVC	PVC
20	Flat Washer (NS)	Hastelloy C	Not Used	Hastelloy C	Hastelloy C
21	Lock Washer (NS)	Hastelloy C	Not Used	Hastelloy C	Hastelloy C
22	Hex Nut (NS)	Hastelloy C	Not Used	Hastelloy C	Hastelloy C
23	Screen-Weatherhood	PVC	PVC	PVC	PVC

* = Recommended Spare Parts
Refer to Fig. 5 & 6 on p. 6 for pallet assembly fastener information.

Groth Model 1220A Pressure/Vacuum Relief Valve

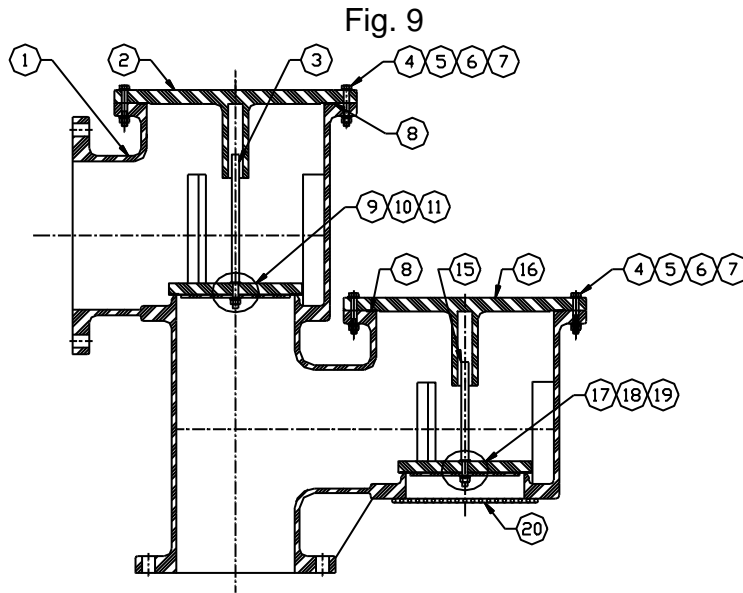

		Epoxy Vinyl Ester Resin			
ITEM	NAME	411-45	411-45 - PVDF	470-36	Furan
1	Body	411-45	411-45	470-36	Furan
2	Cover, Pressure	411-45	411-45	470-36	Furan
3	Stem, Pressure	Alloy C276	PVDF	Alloy C276	Alloy C276
4	Hex Bolt	316 SS	316 SS	316 SS	316 SS
5	Hex Nut	316 SS	316 SS	316 SS	316 SS
6	Flat Washer	316 SS	316 SS	316 SS	316 SS
7	Lock Washer	316 SS	316 SS	316 SS	316 SS
8	* Gasket	Fluoropolymer	Fluoropolymer	Fluoropolymer	Fluoropolymer
9	Pallet, Pressure	411-45	PVDF	470-36	Furan
10	* Diaphragm, Pres.	FEP	FEP	FEP	FEP
11	Ret. Plate, Pres.	411-45	PVDF	470-36	Furan
12	Hex Nut (NS)	Alloy C276	Not Used	Alloy C276	Alloy C276
13	Flat Washer (NS)	Alloy C276	Not Used	Alloy C276	Alloy C276
14	Lock Washer (NS)	Alloy C26	Not Used	Alloy C276	Alloy C276
15	Stem, Vacuum	Alloy C276	PVDF	Alloy C276	Alloy C276
16	Cover, Vacuum	411-45	411-45	470-36	Furan
17	Pallet, Vacuum	411-45	PVDF	470-36	Furan
18	* Diaphragm, Vac.	FEP	FEP	FEP	FEP
19	Ret. Plate, Vac	411-45	PVDF	470-36	Furan
20	Screen (Optional)	PVC	PVC	PVC	PVC
21	Hex Nut (NS)	Not Used	Fluoropolymer	Not Used	Not Used

* = Recommended Spare Parts
 Refer to Fig. 5 & 6 on p. 6 for pallet assembly fastener information.

Groth Model 1260A/1760A Pressure/Vacuum Relief Valve

Fig. 10

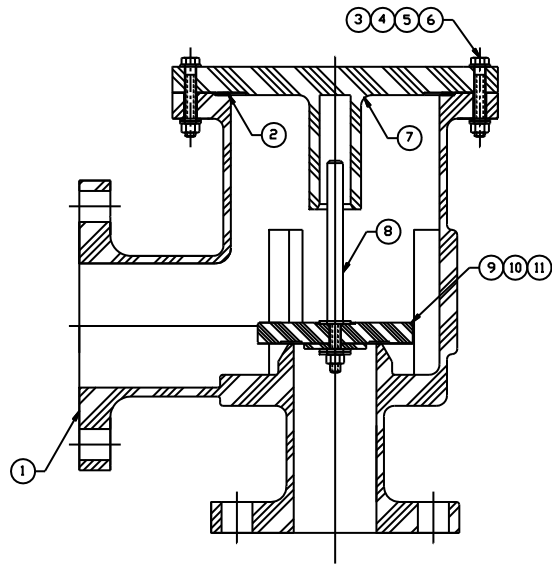

		Epoxy Vinyl Ester Resin			
ITEM	NAME	411-45	411-45 w/ PVDF	470-36	Furan
1	Body	411-45	411-45	470-36	Furan
2	* Gasket	Fluoropolymer	Fluoropolymer	Fluoropolymer	Fluoropolymer
3	Hex Bolt	316 SS	316 SS	316 SS	316 SS
4	Hex Nut	316 SS	316 SS	316 SS	316 SS
5	Flat Washer	316 SS	316 SS	316 SS	316 SS
6	Lock Washer	316 SS	316 SS	316 SS	316 SS
7	Cover	411-45	411-45	470-36	Furan
8	Stem-Pressure	Alloy C276	PVDF	Alloy C276	Alloy C276
9	Pallet	411-45	PVDF	470-36	Furan
10	* Diaphragm	FEP	FEP	FEP	FEP
11	Retainer Plate	411-45	PVDF	470-36	Furan
12	Hex Nut (NS)	Alloy C276	Not Used	Alloy C276	Alloy C276
13	Flat Washer (NS)	Alloy C276	Not Used	Alloy C276	Alloy C276
14	Lock Washer (NS)	Alloy C276	Not Used	Alloy C276	Alloy C276
21	Hex Nut (NS)	Not Used	Fluoropolymer	Not Used	Not Used

* = Recommended Spare Parts

Refer to Fig. 5 & 6 on p. 6 for pallet assembly fastener information.

Groth Model 1300A Pressure/Vacuum Relief Valve

Fig. 11

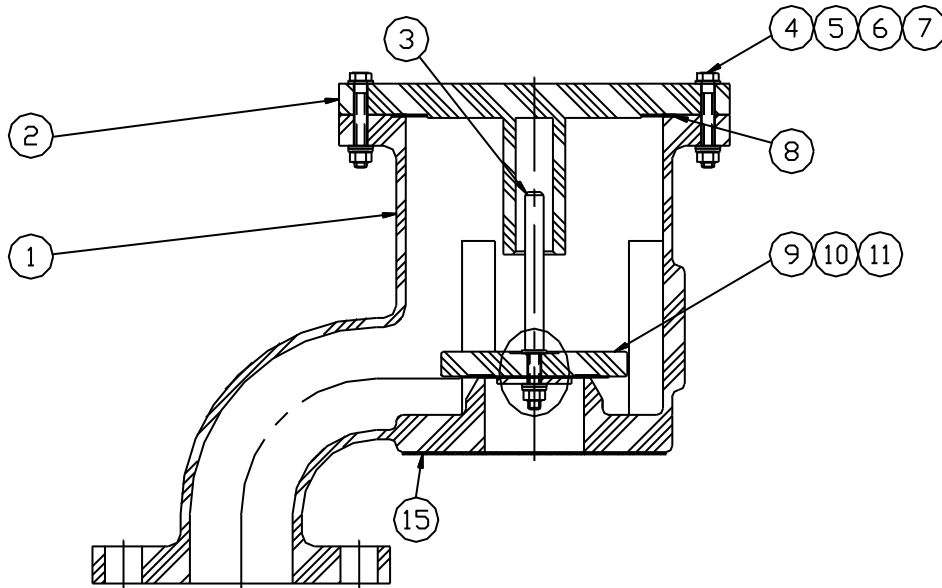

		Epoxy Vinyl Ester Resin				
ITEM		NAME	411-45	411-45 w/ PVDF	470-36	Furan
1		Body	411-45	411-45	470-36	Furan
2		Cover	411-45	411-45	470-36	Furan
3		Stem	Alloy C276	PVDF	Alloy C276	Alloy C276
4		Hex Bolt	316 SS	316 SS	316 SS	316 SS
5		Hex Nut	316 SS	316 SS	316 SS	316 SS
6		Flat Washer	316 SS	316 SS	316 SS	316 SS
7		Lock Washer	316 SS	316 SS	316 SS	316 SS
8	*	Gasket	Fluoropolymer	Fluoropolymer	Fluoropolymer	Fluoropolymer
9		Pallet	411-45	PVDF	470-36	Furan
10	*	Diaphragm	FEP	FEP	FEP	FEP
11		Retainer Plate	411-45	PVDF	470-36	Furan
12		Flat Washer (NS)	Alloy C276	Not Used	Alloy C276	Alloy C276
13		Lock Washer (NS)	Alloy C276	Not Used	Alloy C276	Alloy C276
14		Hex Nut (NS)	Alloy C276	Not Used	Alloy C276	Alloy C276
15		Screen (Opt.)	PVC	PVC	PVC	PVC
21		Hex Nut (NS)	Not Used	Fluoropolymer	Not Used	Not Used

* = Recommended Spare Parts
 Refer to Fig. 5 & 6 on p. 6 for pallet assembly fastener information.

Groth Model 1360A Pressure/Vacuum Relief Valve

Fig. 12

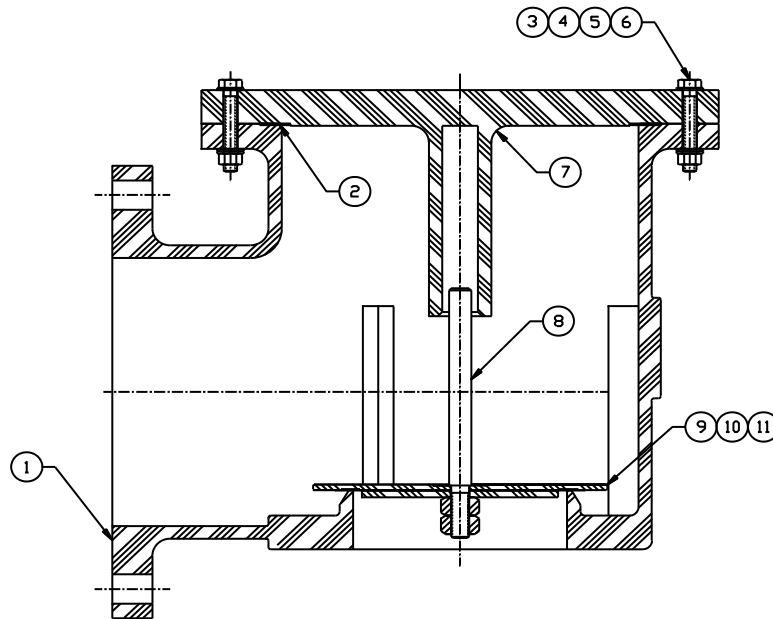

		Epoxy Vinyl Ester Resin			
ITEM	NAME	411-45	411-45	470-36	Furan
1	Body	411-45	411-45	470-36	Furan
2	* Gasket	Fluoropolymer	Fluoropolymer	Fluoropolymer	Fluoropolymer
3	Hex Bolt	316 SS	316 SS	316 SS	316 SS
4	Hex Nut	316 SS	316 SS	316 SS	316 SS
5	Flat Washer	316 SS	316 SS	316 SS	316 SS
6	Lock Washer	316 SS	316 SS	316 SS	316 SS
7	Cover	411-45	411-45	470-36	Furan
8	Stem - Vacuum	Alloy C276	PVDF	Alloy C276	Alloy C276
9	Pallet	411-45	PVDF	470-36	Furan
10	* Diaphragm	FEP	FEP	FEP	FEP
11	Retainer Plate	411-45	PVDF	470-36	Furan
12	Hex Nut (NS)	Alloy C276	Not Used	Alloy C276	Alloy C276
13	Flat Washer (NS)	Alloy C276	Not Used	Alloy C276	Alloy C276
14	Lock Washer (NS)	Alloy C276	Not Used	Alloy C276	Alloy C276
15	Screen (Opt.) (NS)	PVC	PVC	PVC	PVC
21	Hex Nut (NS)	Not Used	Fluoropolymer	Not Used	Not Used

* = Recommended Spare Parts

Refer to Fig. 5 & 6 on p. 6 for pallet assembly fastener information.

Groth Model 2300A Pressure/Vacuum Relief Valve

Fig. 13

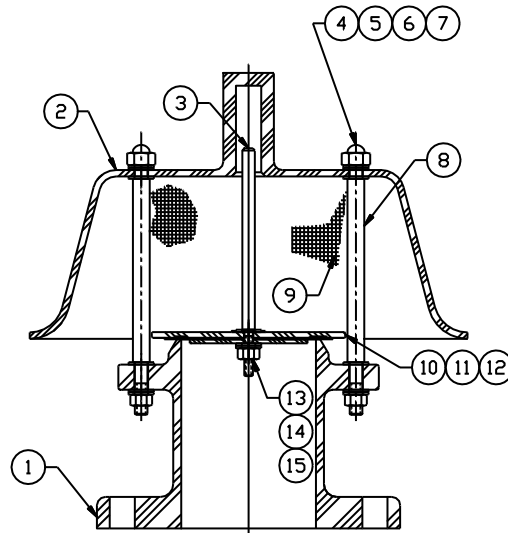

		Epoxy Vinyl Ester Resin			
ITEM	NAME	411-45	411-45 w/ Kynar	470-36	Furan
1	Body	411-45	411-45	470-36	Furan
2	Weatherhood	411-45	411-45	470-36	Furan
3	Stem	Alloy C276	PVDF	Alloy C276	Alloy C276
4	Hex Nut	316 SS	316 SS	316 SS	316 SS
5	Flat Washer	316 SS	316 SS	316 SS	316 SS
6	Lock Washer	316 SS	316 SS	316 SS	316 SS
7	Hex Nut	316 SS	316 SS	316 SS	316 SS
8	Weatherhood Post	Alloy C276	Alloy C276	Alloy C276	Alloy C276
9	Screen	PVC	PVC	PVC	PVC
10	Pallet	411-45	PVDF	470-36	Furan
11	* Diaphragm	FEP	FEP	FEP	FEP
12	Retainer Plate	411-45	PVDF	470-36	Furan
13	Hex Nut	Alloy C276	Not Used	Alloy C276	Alloy C276
14	Flat Washer	Alloy C276	Not Used	Alloy C276	Alloy C276
15	Lock Washer	Alloy C276	Not Used	Alloy C276	Alloy C276
21	Hex Nut (NS)	Not Used	Fluoropolymer	Not Used	Not Used

* = Recommended Spare Parts

Refer to Fig. 5 & 6 on p. 6 for pallet assembly fastener information.

Table 6: LIST OF ABBREVIATIONS

ANSI	American National Standard	Lb.-Ft.	Pound Foot	PRES	Pressure
API	American Petroleum Institute	MAWP	Max Allowable Work,g Press.	P/N	Part Number
cm	Centimeter	mil	Thousands Of An Inch	PSIG	Pounds Per Square Inch
ERV	Emergency Relief Valve	mm	Millimeter	S/N	Serial Number
FRP	Fiberglass Reinforced Plastic	MSDS	Material Safety Data Sheet	SCFH	Standard Cubic Ft Per Hour
In. WC	Inches Of Water Column	OP	Over Pressure	SLV	Spring Loaded Valve
kg	Kilogram	OSI	Ounces Per Square Inch	TVTS	Tank Vent Test Stand
kg.m	kilogram-meter	OZ	Ounces	VAC	Vacuum
Lb.	Pound	NS	Not Shown (on drawing)	WLV	Weight Loaded Valve

Table 7: LIST OF FIBERGLASS RESINS AVAILABLE FOR VALVE BODY CONSTRUCTION:

Resin Name	Manufacturer	Max. Temp. ¹	Comments
Epoxy Vinyl Ester Resin #411-45	Dow Chemical Co.	210° F	Consult factory or Dow Plastics' "Chemical Resistance & Engineering Guide" for detailed information related to specific service recommendations.
Epoxy Vinyl Ester Resin #470-36	Dow Chemical Co.	250° F ²	Consult factory or Dow Plastics' "Chemical Resistance & Engineering Guide" for detailed information related to specific service recommendations.
Furan	Great Lakes Chemical	250° F	Often specified where corrosion resistance to both solvents & acids is required; Consult "QuaCorrResin Catalyst Systems Media Guide."
Hetron 922	Ashland Chemical	225° F.	Excellent resistance to acids, alkalis, hypochlorites and many solvents. Consult factory or Ashland Chemicals' "Chlorendic Polyester & Aropol Resin Selection Guide."
Chlorendic Polyester 197-3	Ashland Chemical	220° F.	Consult factory or Ashland Chemicals' "Chlorendic Polyester & Aropol Resin Selection Guide."
Hetron 800	Ashland Chemical	250° F.	Furan resin; excellent resistance to strong alkalis and acids containing chlorinated organics. Not suitable for oxidizing chemicals; do not use with chromic or nitric acids, peroxides and hypochlorites.

1. General temperature limitation; consult factory for specific service.
2. In some services, max. temperature is 350° F. – 400° F.

The nameplate on the Valve contains the Model Number, Serial Number, set pressures and flow capacity at a specified over-pressure. The Model Number contains additional information about materials of construction, soft goods and options. The following chart will assist in relating the Model Number to the characteristics of your valve:

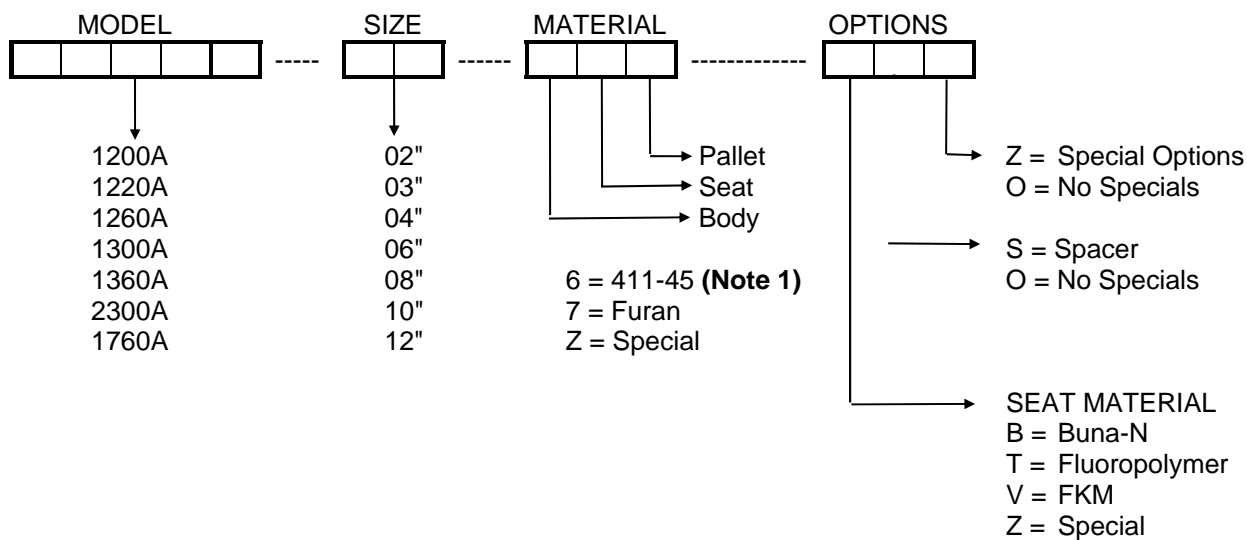

Notes:

1. Epoxy Vinyl Ester Resin 411-45 is standard; 470-36 is available (specify as Z = 470-36 Epoxy Vinyl Ester Resin).
2. Pallet Assemblies include standard Alloy C276 stems unless setting can't be achieved with a lighter material.

EXAMPLE: 1200A-02-666-TOO indicates a 2" Model 1200A with 411-45 Epoxy Vinyl Ester Resin body, seat & pallet assembly, Fluoropolymer seat diaphragms, Alloy C276 internal fasteners, 316 SS external fasteners and no special options.

PRODUCT LIMITED WARRANTY

- A. Seller warrants that products which are manufactured by Seller, are manufactured in accordance with published specifications and free from defects in materials and/or workmanship for a period of (12) twelve months. Seller, at its option, will repair or replace any products returned intact to the factory, transportation charges prepaid, which Seller, upon inspection, shall determine to be defective in material and/or workmanship. The foregoing shall constitute the sole remedy for any breach of Seller's warranty.
- B. THERE ARE NO UNDERSTANDINGS, AGREEMENTS, REPRESENTATIONS, OR WARRANTIES, EXPRESS OR IMPLIED, (INCLUDING MERCHANTABILITY OR FITNESS FOR A PARTICULAR PURPOSE REGARDING PRODUCTS) UNLESS SPECIFIED IN THE SALES CONTRACT. THIS CONTRACT STATES THE ENTIRE OBLIGATION OF SELLER.
- Seller makes no warranties, either express or implied, except as provided herein, including
- without limitation thereof, warranties as to marketability, merchantability, for a particular purpose or use, or against infringement of any patent of products. In no event shall Seller be liable for any direct, incidental or consequential damages of any nature, or losses or expenses resulting from any defective new product or the use of any such product, including any damages for loss of time, inconvenience, or loss of use of any such product.
- C. The original Manufacturer shall be solely responsible for the design, development, supply, production, and performance of its products hereunder, and the protection of its trade name or names, if any. It assumes no responsibility, for products modified or changed in any way by its agent or customer. Any such modifications or changes to products sold by Seller hereunder shall make the product limited warranty null and void.
- D. The Manufacturer shall be under no obligation to manufacture, sell, or supply, or to continue to manufacture, sell or supply any of the Products.

TABLE 5 - Maximum Vacuum Settings with Resin Encapsulated Lead Weights

Valve Size	OSI	IN WC	mbar
2"	28	48.4	121
3"	32	55.4	138
4"	32	55.4	138
6"			
8"			
10"			
12"			

WARNING: Table 5 is based on limiting the dimensions of the pallet weight to ensure that the valve will achieve rated flow capacity. For most valves, a lead weight is molded integral with the pallet. DO NOT add additional weight to the pallet assembly without consulting the factory as pallet lift could be restricted. Pallet lift restriction can cause the tank to be over-pressured to achieve the valves' rated flow capacity.

Size	Pressure				Vacuum			
	FRP/Hast	Min. Set	PVDF	Min. Set	FRP/Hast	Min. Set	PVDF	Min. Set
2"	KPAP02_6	1.63 OSI	KPAP0224	0.51 OSI				
3"	KPAP03_6		KPAP0324					
4"	KPAP04_6		KPAP0424					
6"	KPAP06_6		KPAP0624					
8"	KPAP08_6		KPAP0824					
10"	KPAP10_6		KPAP1024					
12"	KPAP12_6		KPAP1224					

Size	Pressure				Vacuum			
	FRP/Hast	Min. Set	PVDF	Min. Set	FRP/Hast	Min. Set	PVDF	Min. Set
2"	KPAP026							
3"								
4"								
6"								
8"								
10"								
12"								